



Visit [www.mcicoach.com](http://www.mcicoach.com) for money saving specials!



Enjoy savings on Heavy Duty Wiper Blades, Zafety Lug Lock™ and special savings on Webb Brake Drums using Vortex Technology!



**MOTOR COACH**  
INDUSTRIES

*Welcome to the **MC**ILEARN Series*

*Your Webinar Will Begin Shortly*

Today's Topic:  
Ladder Logic for MUX

If you do not have an audio connection, please dial 866-339-6642 and enter \*8173541434\*. The stars must be entered

Zafety Lug Lock™ is a trademark of SPECTRA Products  
© 2011 Motor Coach Industries, Inc. All Rights Reserved.

# Agenda

---

- Coach Circuits - Then vs. Now
- Module Details
  - Connectors
  - Address
- It's Math Time - Woo Hoo!
- New Symbols
- Time for "Advanced Calculus"

# SAFETY

- Practice general safety procedures
- Always wear safety glasses
- Use test equipment properly
- Use care when working around belt driven accessories
- As batteries contain acid, the correct clothing should be worn when handling batteries
- Care should be used dealing with electricity, as shocks can occur

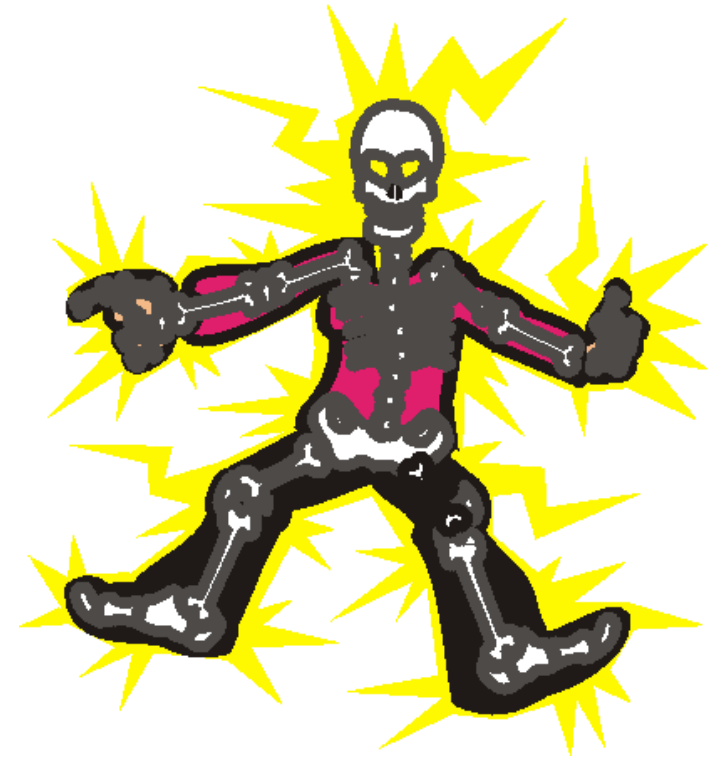



**MOTOR COACH**  
INDUSTRIES

## Coach Circuits - Then vs. Now

# Times Have Changed

---

- Troubleshooting MUX begins in your approach to the issue.
  - Common Practice before MUX was to check for power at the switch and work down the circuit.
  - Now with MUX there is a new approach to troubleshooting.
- Electrical Basics still apply, but the circuit structure has changed

# Circuit Diagnosing - Before

- Battery power flows through the entire circuit
  - Troubleshooting practice is to follow the power

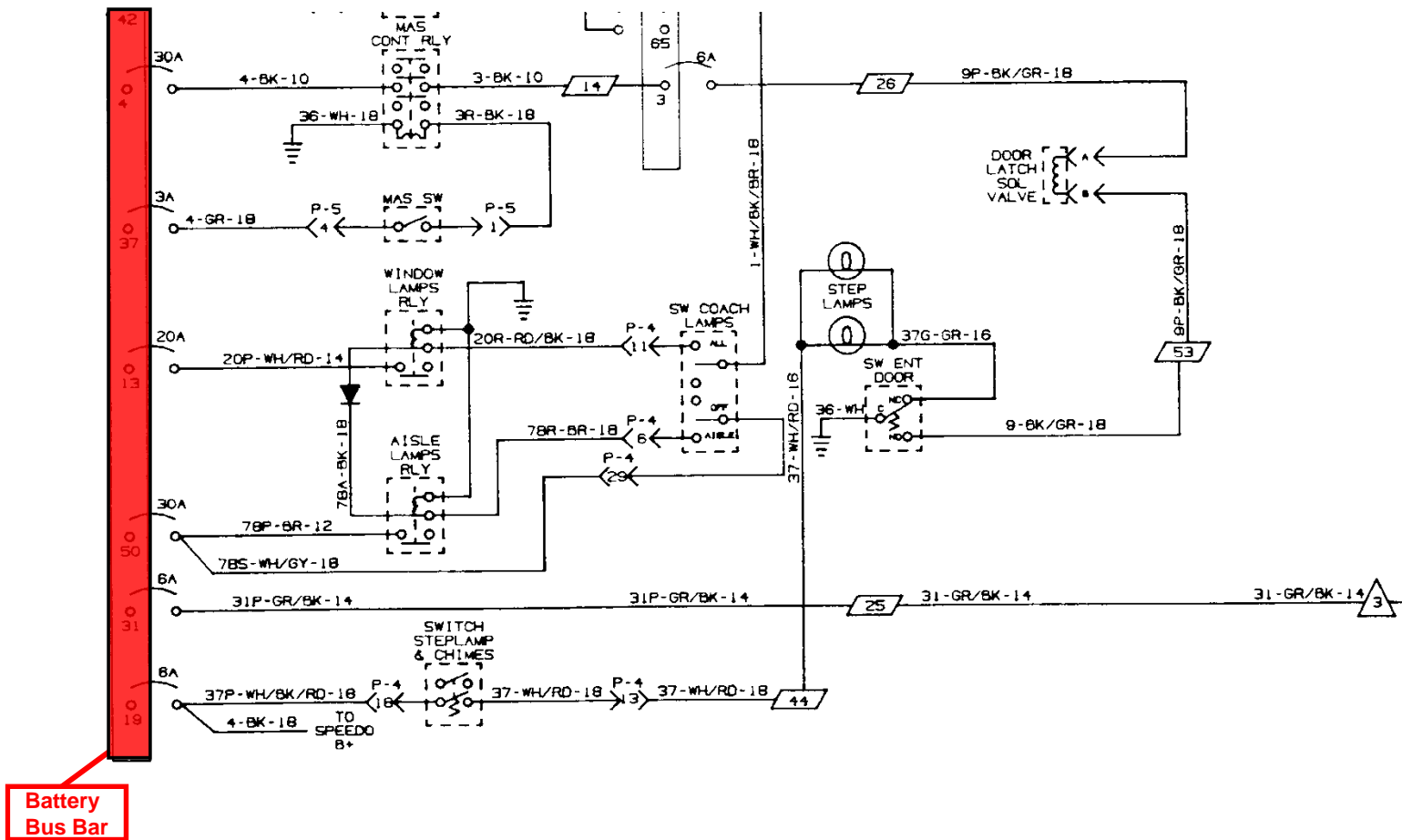

# Circuit Diagnostics - NOW

## INPUTS

## MODULE

## OUTPUTS



- Now the circuit is broken into 3 separate sections
  - Inputs
  - Outputs
  - Module

***Remember there is no direct connection between the inputs and outputs***



MOTOR COACH  
INDUSTRIES

## Module Details

- Connectors
- Address



MOTOR COACH  
INDUSTRIES

## Module Configuration

- This type of module is divided into 2 halves
  - Input
  - Output
- Each input and output is a separate “user” that has a specific job to perform

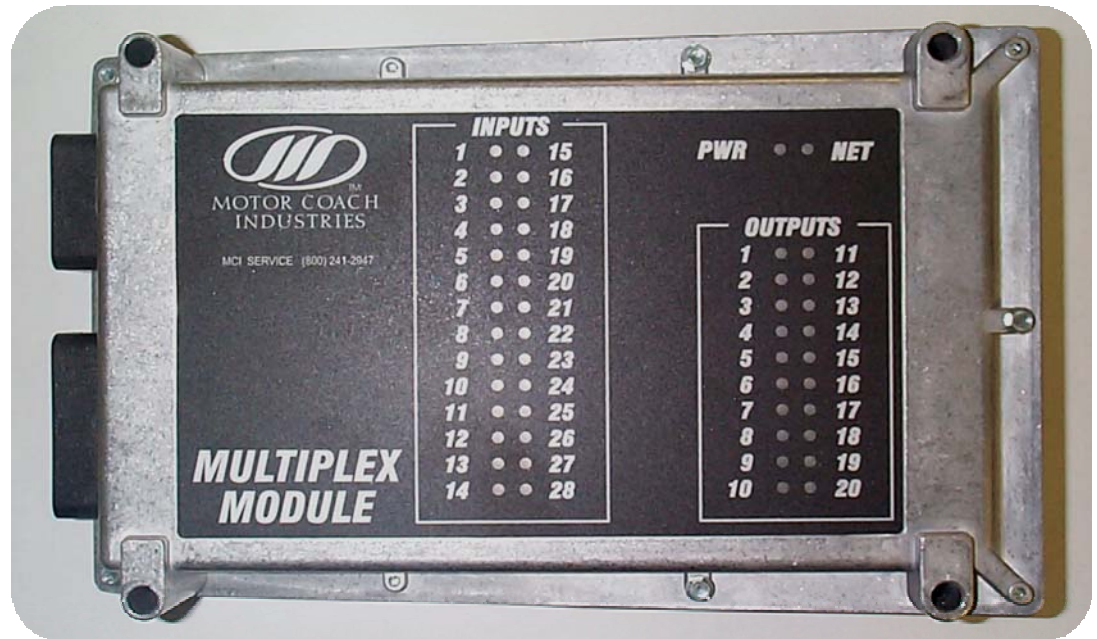

48 “Users” / Module

# Multiplex Module Connections

Each module has four connectors, located on the LH & RH sides

- A = Inputs 6-28
- B = Inputs 1-5, Power/Ground, Address Pins, J1939
- C = Outputs
- Power Connector (Load Pins)

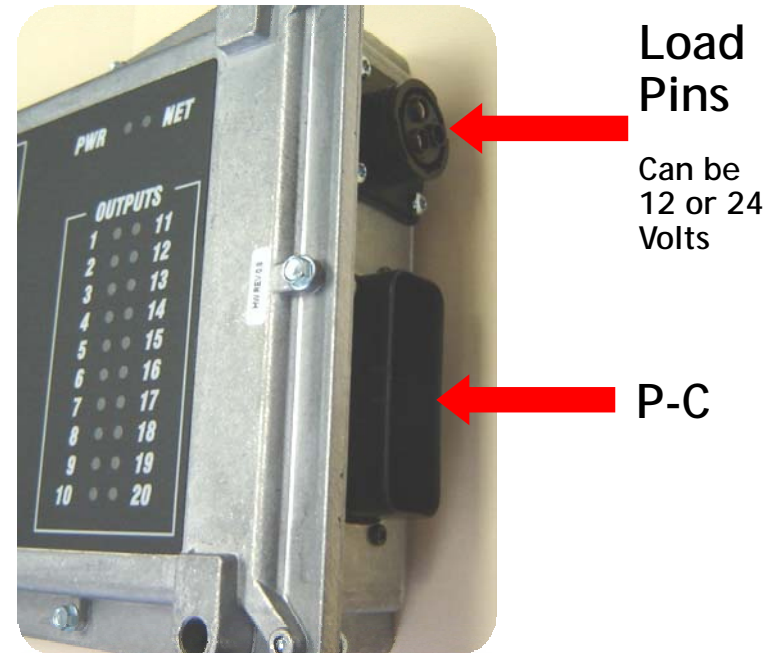
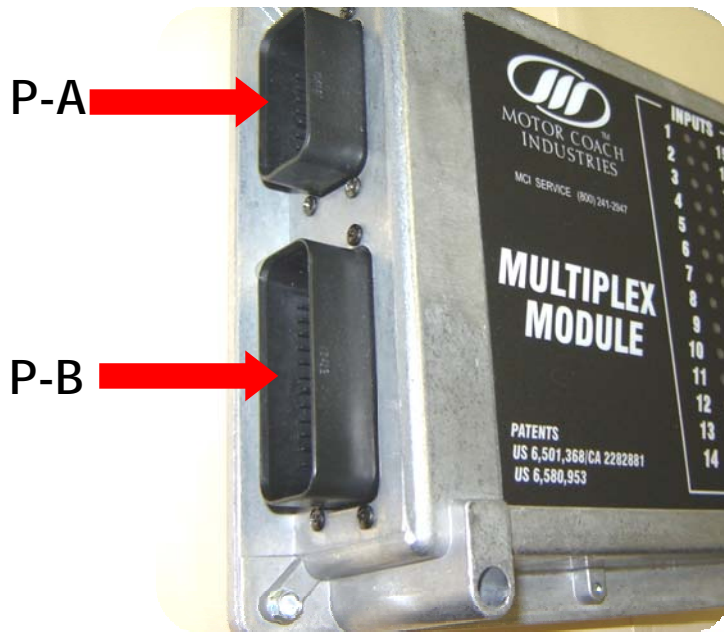

## Multiplex Module Designations

Each Module has it's own address. This is accomplished through the Address Pins Numbers 13 thru 17 on the module "B" connector

	V1	V2	V3	V4	V5	V6	V7	V8
Pin 13		◆		◆		◆	◆	
Pin 14			◆	◆			◆	
Pin 15					◆	◆	◆	
Pin 16								◆
Pin 17								



**MOTOR COACH**  
INDUSTRIES

## Quiz 1



MOTOR COACH  
INDUSTRIES

## Answers to Quiz 1

---

- Plug A on a VMM is for outputs only.
  - FALSE
- VMMs have 20 outputs per module.
  - TRUE
- Pins 13 - 17 in plug B determine the VMM's address.
  - TRUE
- The troubleshooting techniques are the same for pre Multiplex systems and Multiplex systems.
  - FALSE



**MOTOR COACH**  
INDUSTRIES

## Ladder Logic (Math Time)



MOTOR COACH  
INDUSTRIES

## Multiplexing Ladder Logic



Ladder Logic is a grouping of (*weird*) symbols that allows the user to put on paper the instructions the outputs use to function (*just like a math formula*).



MOTOR COACH  
INDUSTRIES

# Multiplexing Ladder Logic



## Basic Math

$$1 + 1 = 2$$

# MCI Multiplexing

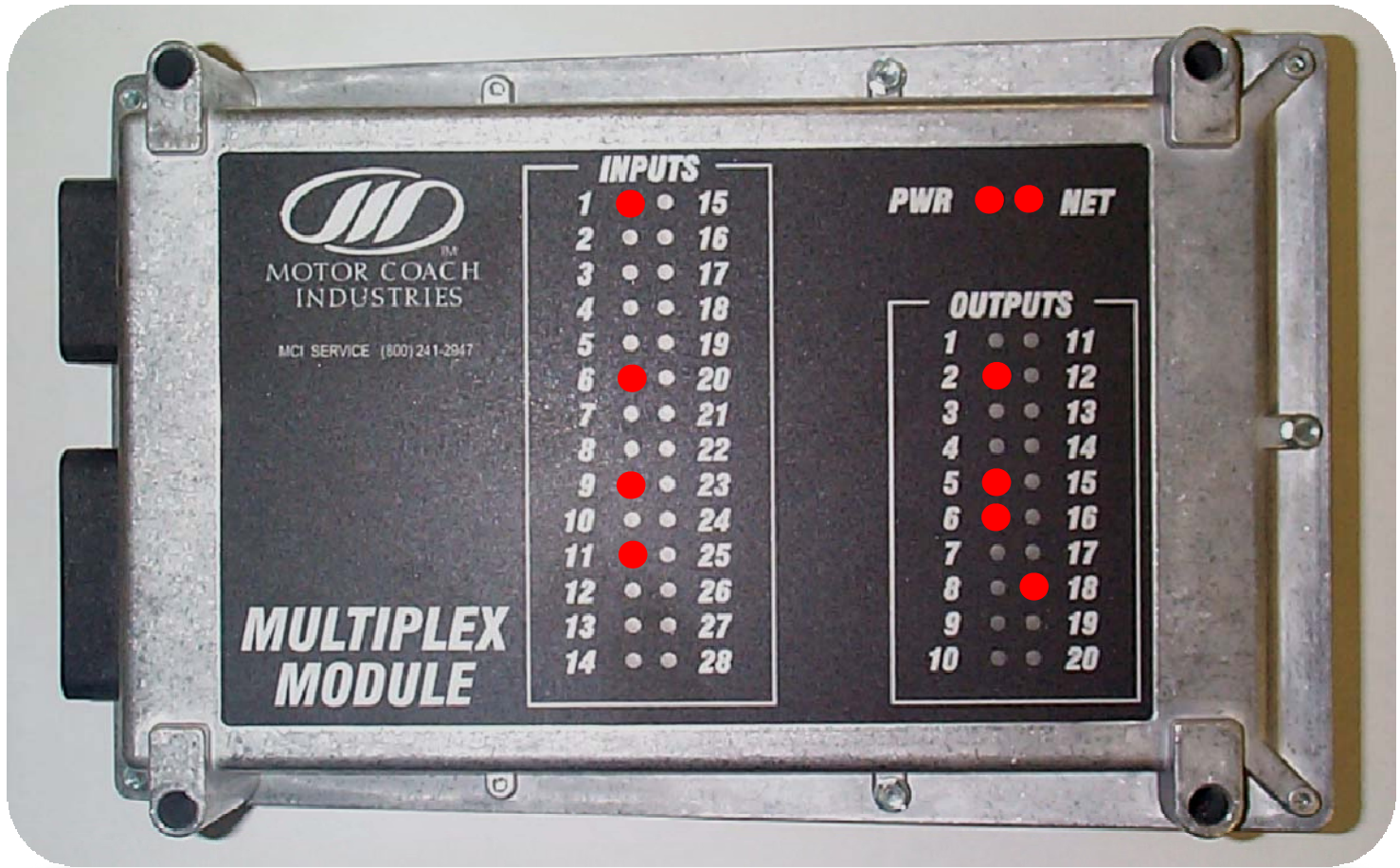

## Multiplexing Ladder Logic - Inputs

---



- Two vertical, parallel lines
- Module LED location (I3-1)
- Function Description (Master 2)
- Represents two states
  - Active - as shown
  - Inactive, diagonal line drawn through symbol

## Multiplexing Ladder Logic - Outputs

---

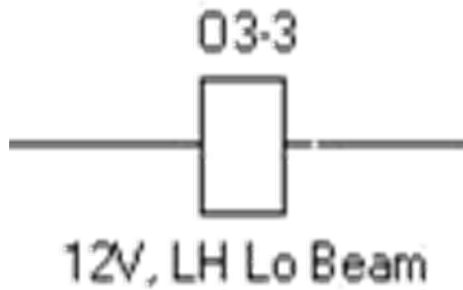

- Rectangle
- Module LED location (03-3)
- Function Description (12V, LH Lo Beam)

# Input Symbol vs. Input T/T on Module

V3 = Module Number  
Located Front J-Box  
location 2

V2 = Module Number 1 Ft. J-Box  
V3 = Module Number 2 Ft. J-Box  
V5 = Module Number 3 Rear Left Parcel Rack  
(Units 62032 thru 64449)

I = Input

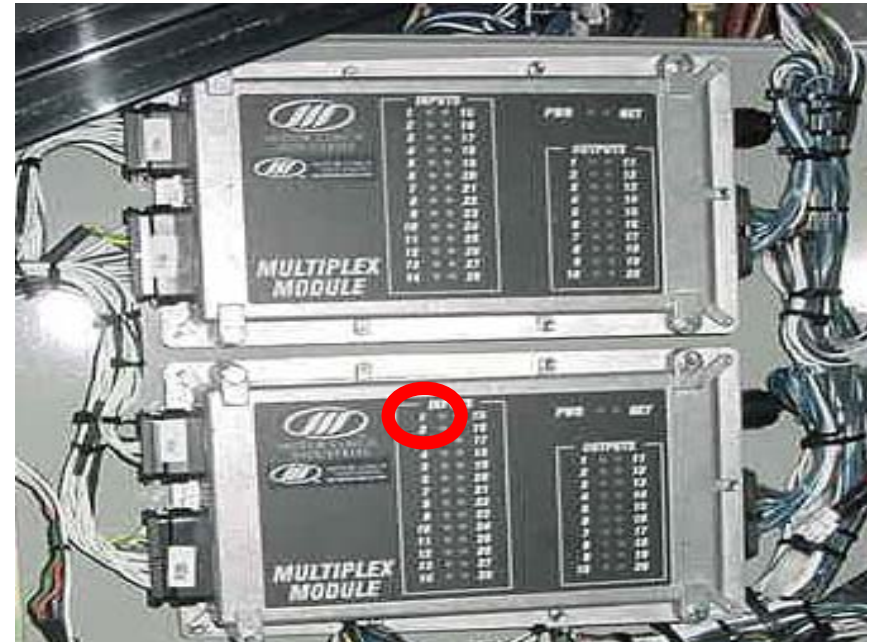
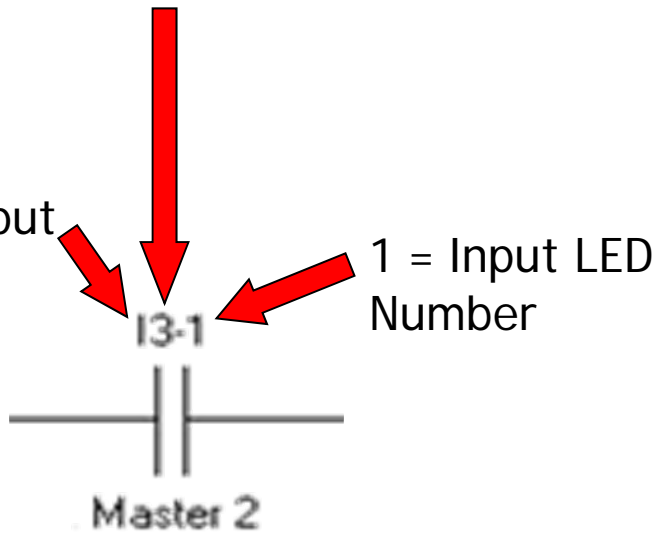

D Model = Module # & Address the same  
E/J Model/ eff. 64450 = Module # & Address  
the same

# Output Symbol vs. Output T/T on Module

V3 = Module Number  
Located Front J-Box  
location 2

0 =  
Output  
Signal

3 = Output LED  
Number

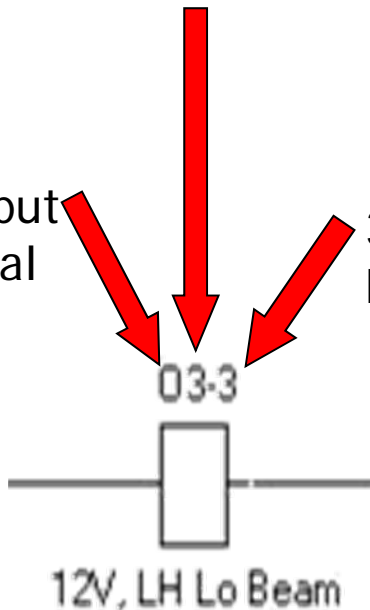

V2 = Module Number 1 Ft. J-Box

V3 = Module Number 2 Ft. J-Box

V5 = Module Number 3 Rear Left Parcel Rack

(Units 62032 thru 64449)

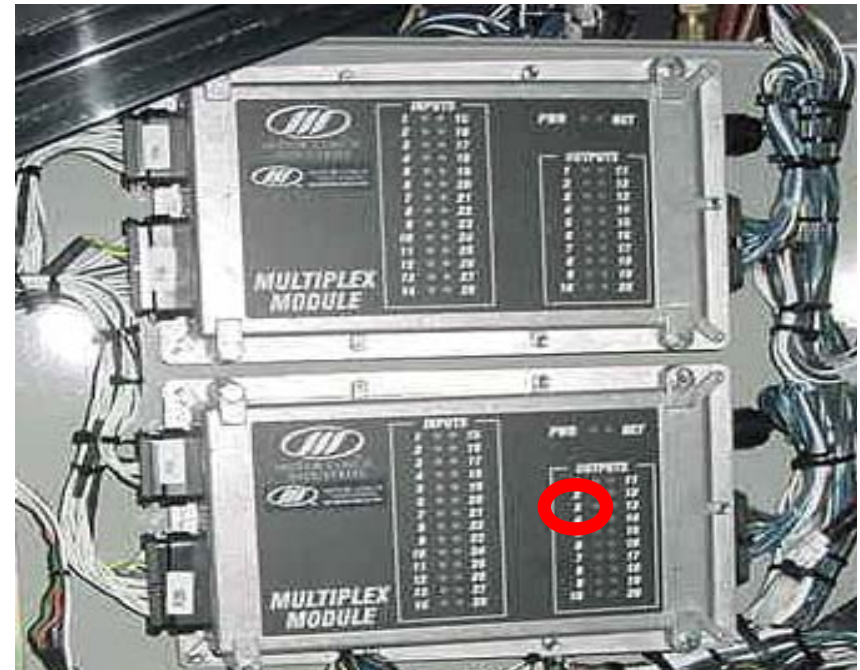

D Model = Module # & Address the same

E/J Model/ eff. 64450 = Module # & Address  
the same



MOTOR COACH  
INDUSTRIES

## New Symbols



MOTOR COACH  
INDUSTRIES

# Multiplexing Ladder Logic - *Getting Busier*

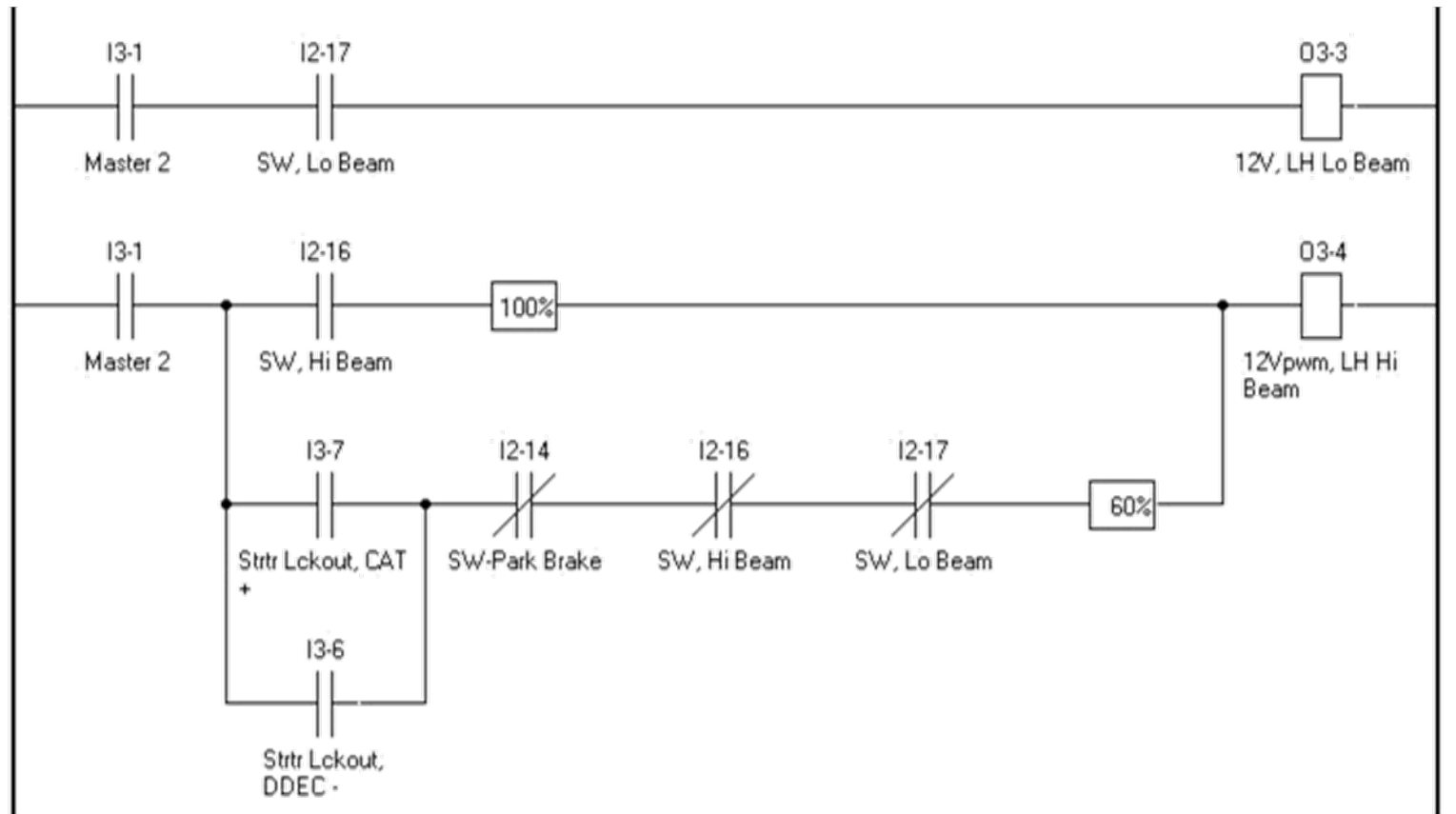

# Multiplexing Ladder Logic - Symbols

## Input



## Output

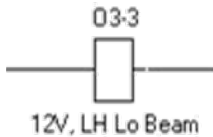

## Flag

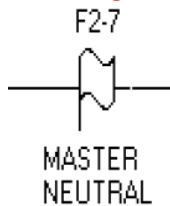

## Dash T/T

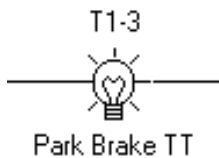

## Timers

(4 types)

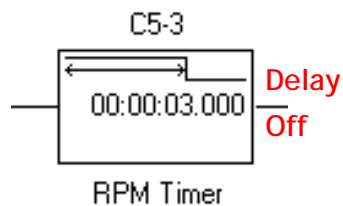
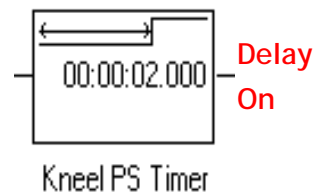
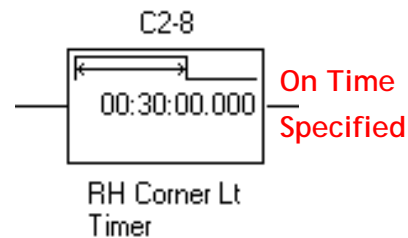
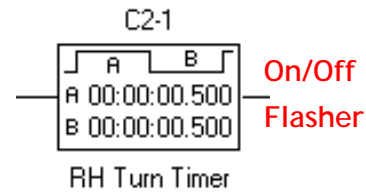

## Math Symbol

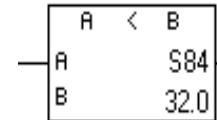

## J1939 Data



## Analog

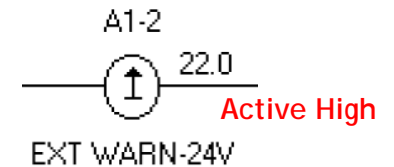
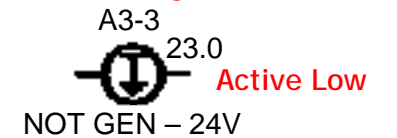

## PWM





**MOTOR COACH**  
INDUSTRIES

## Advanced Logic

# Ladder Logic Basic Rules

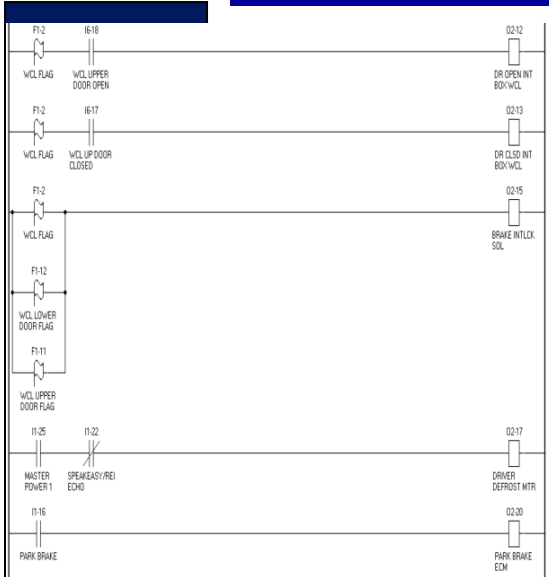

23

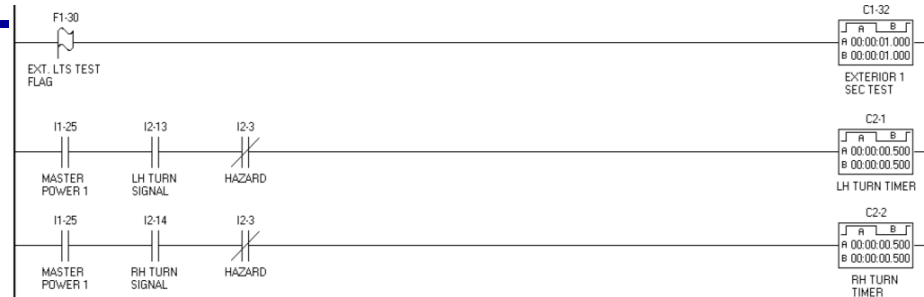
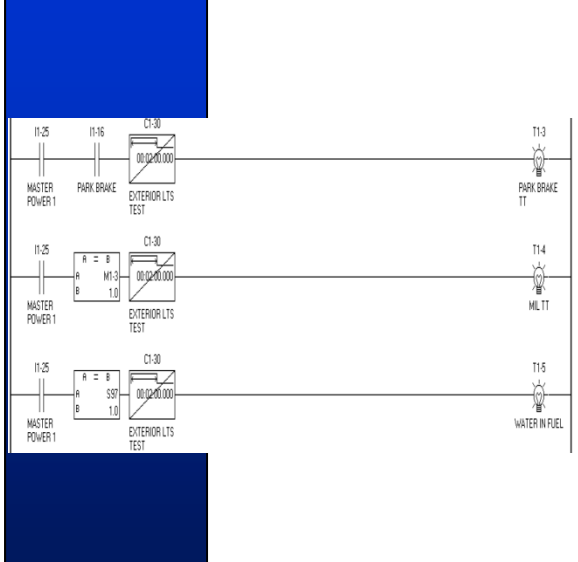

- Module Pin-outs on first pages
- Logic diagrams are arranged alphabetically/numerically according to the Output (RH) side of the diagram
  - Counters
  - Flags
  - Log Files
  - Outputs
  - Tell Tales
- Depending on logic complexity, information may be on several different pages.

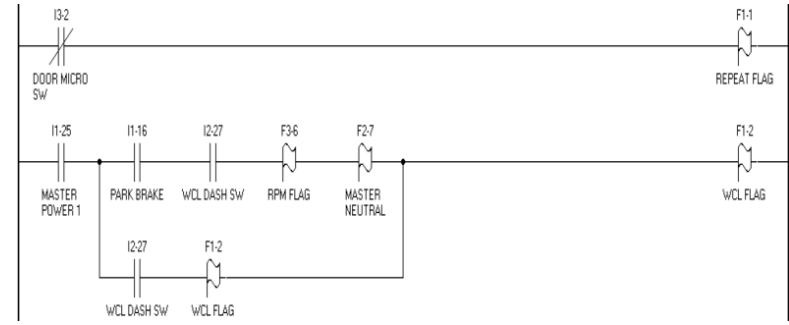



# Module Pinout Chart - 1<sup>st</sup> pages of the Ladder Logic

**A Connector = J2**  
**B Connector = J1**  
**C Connector = J3**

**There is no "generic" program for all coaches/customers, logic is VIN specific**

Master 2	INPUT1 (J1-1)	(J4-1) OUT1-9 BUS	POWER
Batteries Chrgn2	INPUT2 (J1-2)	(J3-6) OUTPUT1	12V, LH Corner Light
Hazard 2	INPUT3 (J1-3)	(J3-5) OUTPUT2	12Vpwm, LH Side Lts
Clearance Lights 2	INPUT4 (J1-4)	(J3-4) OUTPUT3	12V, LH Lo Beam
Service Light SW	INPUT5 (J1-5)	(J3-3) OUTPUT4	12Vpwm, LH Hi Beam
Strtr Lckout, DDEC -	INPUT6 (J1-6) (AL)	(J3-2) OUTPUT5	12V, RH Fog
Strtr Lckout, CAT +	INPUT7 (J1-7) (AH)	(J3-1) OUTPUT6	12V, RH/LH RR Stop
Not Gen 1 +	INPUT8 (J1-8) (AH)	(J3-13) OUTPUT7	12V,Clr/Tail/Lic Lts
Not Gen 2 -	INPUT9 (J1-9) (AL)	(J3-24) OUTPUT8	12Vpwm, LH RR Turn
SPARE	INPUT10 (J1-10)	(J3-25) OUTPUT9	SPARE
SW, LH Turn	INPUT11 (J1-11)	(J4-2) OUT10-18 BUS	POWER
Rear Rise	INPUT12 (J1-12)	(J3-7) OUTPUT10	24V, Driver's Light
SW, Step Light	INPUT13 (J2-1)	(J3-8) OUTPUT11	24V, Step Light
SW, Aisle Light 1/2	INPUT14 (J2-2)	(J3-9) OUTPUT12	24V, Door Claw
SW, Crank	INPUT15 (J2-3)	(J3-10) OUTPUT13	24V, Service Lights
Tag, Unload	INPUT16 (J2-4)	(J3-11) OUTPUT14	24V, Svc Brk-ECAS
RR Start	INPUT17 (J2-5)	(J3-12) OUTPUT15	24V, Starter
SW, Lo Air	INPUT18 (J2-6)	(J3-23) OUTPUT16	24V, RR Rise
Engine Brake Disable	INPUT19 (J2-7)	(J3-35) OUTPUT17	24V, Tag Unload
Retarder Applied	INPUT20 (J2-8)	V3	
Door Closed Sensor	INPUT21 (J2-9)	7JB.07-18-1035E_prk (J3-34) OUTPUT18	SPARE
SW, Driver's Light	INPUT22 (J2-10)	(J3-26) OUTPUT19A	GROUND
SW, Fog Lamp	INPUT23 (J2-11)	(J3-27) OUTPUT19B	Shift Inhibit
Aisle Light All	INPUT24 (J2-12)	(J3-33) OUTPUT20A	GROUND
Rear Rise Recover	INPUT25 (J2-13)	(J3-32) OUTPUT20B	Test
SPARE	INPUT26 (J2-14)	(J1-13) ADDRESS1	NC
SPARE	INPUT27 (J2-15)	(J1-14) ADDRESS2	GROUND
SPARE	INPUT28 (J2-16)	(J1-15) ADDRESS3	NC
WCL Inhib-24V	ANALOG1 (J1-18)	(J1-16) ADDRESS4	NC
High Ride TT-24V	ANALOG2 (J1-19)	(J1-17) ADDRESS5	NC
SPARE	ANALOG3 (J2-17)	(J1-24) +VBAT	POWER
		(J1-25) +VBAT	POWER
		(J1-26) +VBAT	POWER
		(J1-27) GND	GROUND

# Multiplexing Ladder Logic

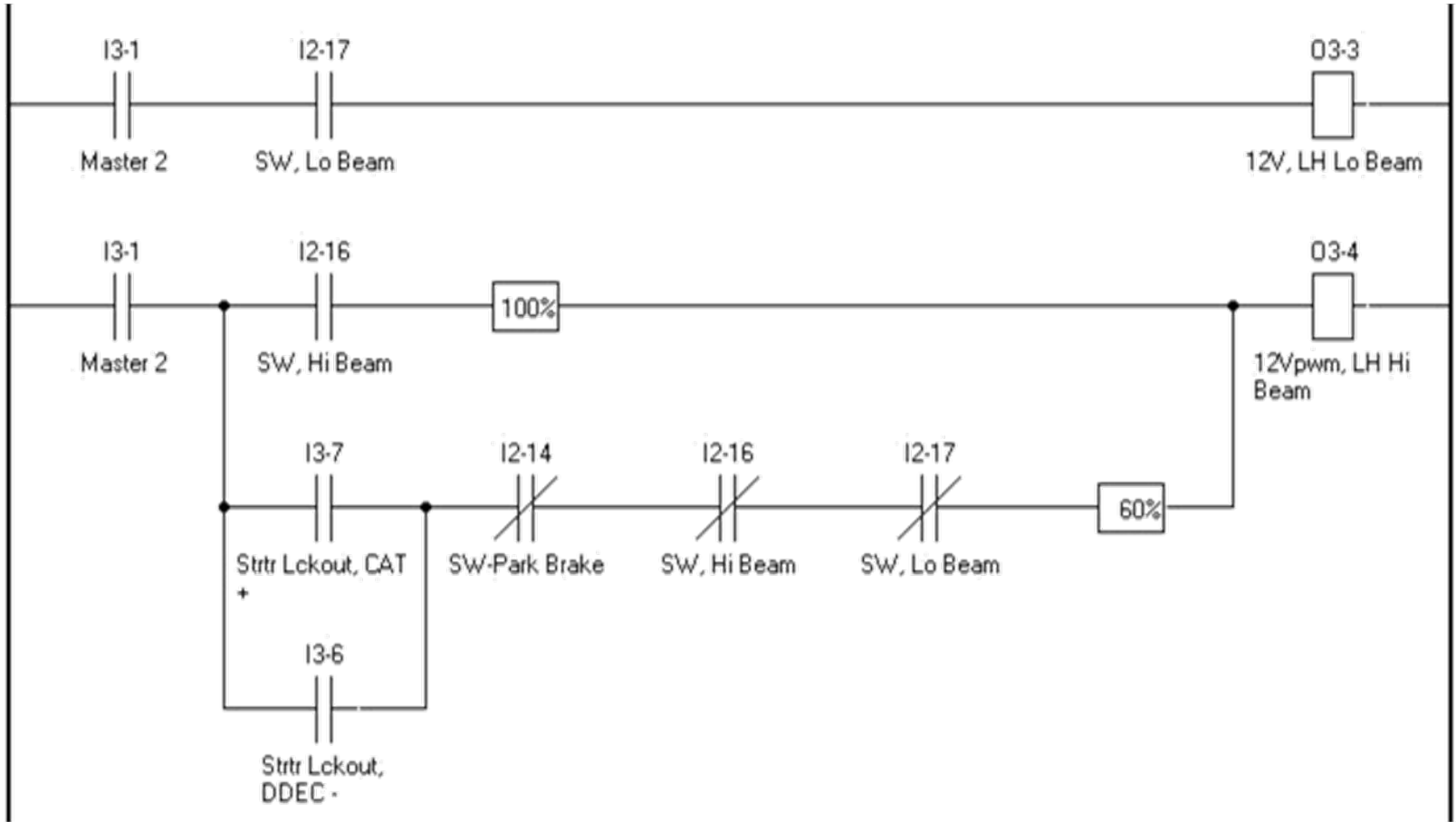

# Multiplexing Ladder Logic

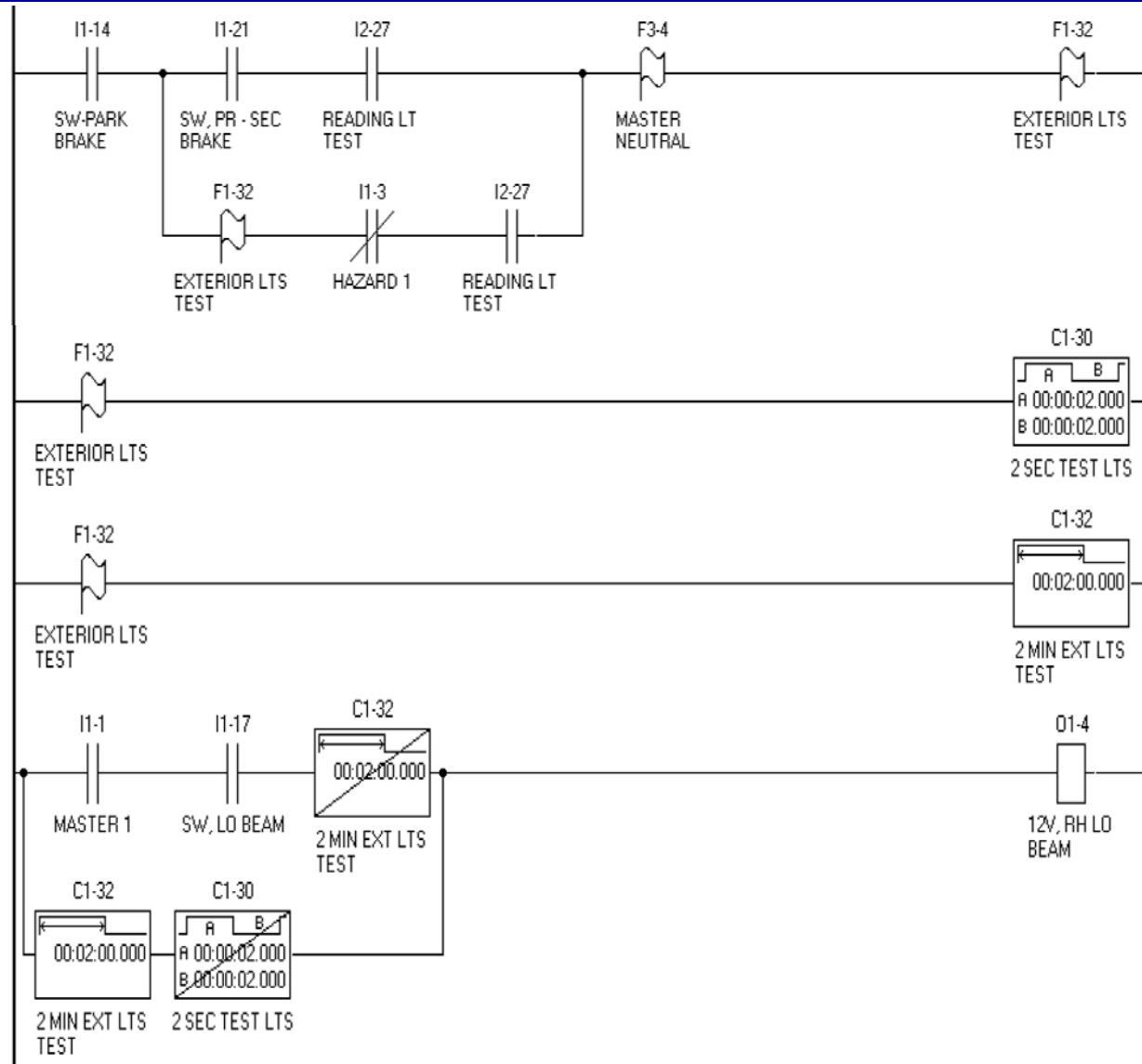



**MOTOR COACH**  
INDUSTRIES

## Quiz 2



MOTOR COACH  
INDUSTRIES

## Answers to Quiz 2

---

- A slash across two vertical parallel lines indicates the switch is active.
  - False
- No slash across two parallel lines indicate the switch is inactive.
  - FALSE
- PWM is an abbreviation for Pulse Width Motor.
  - FALSE
- Flashers are represented by two time lines contained within a rectangle.
  - TRUE



**MOTOR COACH**  
INDUSTRIES

## Questions and Answers

Press the \* on your phone to ask your question



**MOTOR COACH**  
INDUSTRIES

Thank you for your business